

# SmartGATE™ Single Door Upright Ice Storage Bins

## SPECIFICATIONS

*Non-corroding poly liners on all models!  
Industry-exclusive inner SmartGATE!*



SG1350-56

### Poly ice access door assembly

- No sharp corners
- Saves aisle space — only 8" (204mm) deep
- Removes with only 3 screws, no sealant

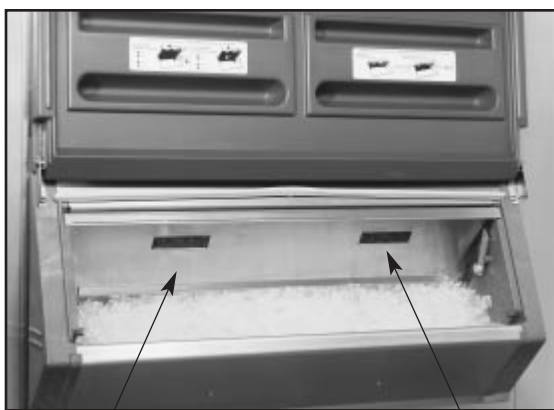

Only **SmartGATE** positively controls ice flow into access door area for increased safety, reduced spillage.

Safely loosen congealed ice through SmartGATE with optional Ice Probe accessory. Released ice remains behind SmartGATE.

Job: \_\_\_\_\_

Item: \_\_\_\_\_

Moderate capacity ice storage bins with industry-exclusive SmartGATE for use with all major commercial icemakers. Stainless exterior includes stainless back and bottom. All bins include stainless tops custom cut for icemaker(s) and 6" (153mm) adjustable legs.

### Wide range of sizes to meet varied needs

- Ten models in widths from 30" to 60" (762 to 1524mm) and capacities from 460 to 1660 lbs (209 to 753kg)

### Industry-exclusive inner SmartGATE delivers more safety, less spillage

- Positively controls ice flow into access door area for easy removal with either scoop or shovel
- Allows loosening of congealed ice without lifting gate for increased safety and reduced spillage
- Locks up in 3 positions
- Returns easily to full down position

### Durable polyethylene lift doors with PowerHinge

- Doors stay safely open without catches
- No sharp corners to injure workers
- Molded-in gasket never needs replacing

### Poly ice access door assembly

- Withstands heavy abuse in critical area
- Eliminates rusting and corrosion

### Non-corroding poly liners

- Eliminates liner pitting and staining
- Makes cleaning easy

### Other quality construction features

- Heavy-duty welded construction
- Non-CFC foamed-in-place insulation
- Translucent double-wall poly windows
- Stainless tops custom cut for specific icemaker(s)

### Optional accessories

- SmartCart 75 with 3 Totes
- Ice paddle and hanging bracket
- Plastic shovel
- Drain pan (required for some Vogt and Howe icemakers; consult factory)
- Stainless legs
- Stainless legs with flanged feet (standard on SG500 and SG700)
- Centered bin partition

# SmartGATE™ Single Door Upright Ice Storage Bins

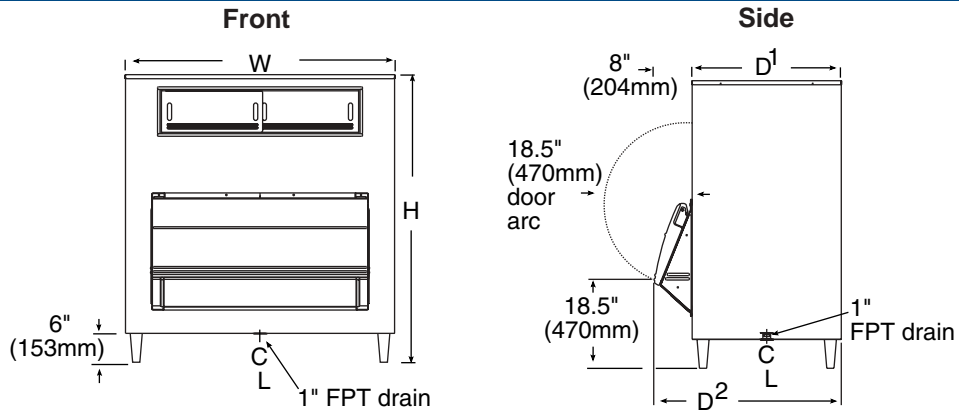

U.S. Patent 5,797,514  
Other patents pending

Follett recommends installation of a floor drain with grate with all ice storage bins.

Model Number	Cu. Vol. (cu ft/m)	Max. Bin Cap. <sup>1</sup>	Width (W)	Depth (D <sup>1</sup> )	Depth w/ Door (D <sup>2</sup> ) <sup>2,3</sup>	Height w/ Legs <sup>4</sup>	Req'd Door Access <sup>5</sup>	Ship. Wt. <sup>2</sup>
<b>SG500-30</b>	14.8 .41	460 lbs 209 kg	30" 762 mm	31" 788 mm	39" 991 mm	43" 1093 mm	31" 788 mm	208 lbs 94 kg
<b>SG700-30</b>	21.7 .61	680 lbs 308 kg	30" 762 mm	31" 788 mm	39" 991 mm	58.5" 1486 mm	31" 788 mm	251 lbs 114 kg
<b>SG1010-48</b>	31.9 .90	1000 lbs 454 kg	48" 1220 mm	31" 788 mm	39" 991 mm	54.5" 1385 mm	32" 813 mm	330 lbs 150 kg
<b>SG1175-48</b>	37.6 1.06	1185 lbs 538 kg	48" 1220 mm	31" 788 mm	39" 991 mm	60.5" 1537 mm	32" 813 mm	347 lbs 157 kg
<b>SG1300-48</b>	41.9 1.19	1320 lbs 599 kg	48" 1220 mm	31" 788 mm	39" 991 mm	64.5" 1639 mm	32" 813 mm	363 lbs 165 kg
<b>SG1160-56</b>	37.3 1.06	1170 lbs 531 kg	56" 1423 mm	31" 788 mm	39" 991 mm	54.5" 1385 mm	32" 813 mm	355 lbs 161 kg
<b>SG1350-56</b>	43.2 1.22	1360 lbs 617 kg	56" 1423 mm	31" 788 mm	39" 991 mm	60.5" 1537 mm	32" 813 mm	370 lbs 168 kg
<b>SG1325-60</b>	42.0 1.19	1325 lbs 601 kg	60" 1524 mm	31" 788 mm	39" 991 mm	54.5" 1385 mm	32" 813 mm	370 lbs 168 kg
<b>SG1475-60</b>	47.4 1.34	1490 lbs 676 kg	60" 1524 mm	31" 788 mm	39" 991 mm	60.5" 1537 mm	32" 813 mm	373 lbs 169 kg
<b>SG1650-60</b>	52.8 1.50	1660 lbs 753 kg	60" 1524 mm	31" 788 mm	39" 991 mm	64.5" 1639 mm	32" 813 mm	399 lbs 181 kg

- Notes:**
- <sup>1</sup> Computed on cubic volume and does not reflect voids that can occur due to pyramiding.
  - <sup>2</sup> Add 2" (51mm) to depth and 10 lbs (4.5kg) to ship weight when drain pan required.
  - <sup>3</sup> Door assemblies remove easily (3 screws, no sealant) if required for installation access.
  - <sup>4</sup> Special top required for icemakers weighing more than 1000 lbs (454kg). Add 2.125" (54mm) to height. Contact factory.
  - <sup>5</sup> Required clearance for installation access through doors (may require removal of door assembly).

## Specifications

Ice storage bin to be Follett model \_\_\_\_\_ with industry-exclusive SmartGATE™ access door design. Cubic capacity to be \_\_\_\_\_, to hold approximately \_\_\_\_\_, lbs/kg of ice. Construction to be welded steel shell and frame. Exterior finish to be stainless, front, sides, back and bottom. Bin liner on all models except SG700-30 to be seamless, heavy-duty, non-corroding polyethylene. Model SG500-30 and SG700-30 liner to have poly walls and stainless bottom. Bin insulation to be non-CFC polyurethane foam. Bin top to be stainless and custom cut for icemaker(s) to be used. Lower door assembly to include non-corroding poly snout, poly lift door with PowerHinge to eliminate gasket and latches and inner SmartGATE™ to positively control ice flow into snout area and reduce spillage. Entire lower door assembly to be easily removable with 3 screws for installation through narrow doors. Upper inspection doors (on all models except SG500-30) to be double-wall poly to increase durability and minimize meltage and condensation. Bin to have 6" (153mm) legs, adjustable to 7.5" (191mm) except models SG500-30 and SG700-30 which have 6" (153mm) stainless legs with flanged feet, adjustable to 7.5" (191mm). Bin drain to be 1" (26mm) FPT rigid PVC. Bin to be NSF listed.

Follett reserves the right to change specifications at any time without obligation. Certifications may vary depending on country of origin.